

Rebate Mounting

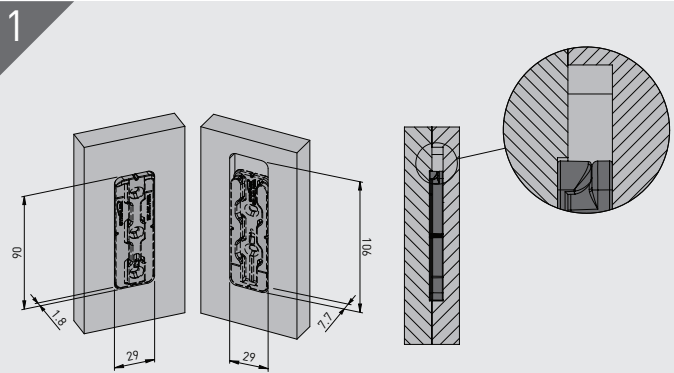

Part Rebate - each substrate mounting face is rebating as shown. Ensure sufficient screw embedment in substrate.

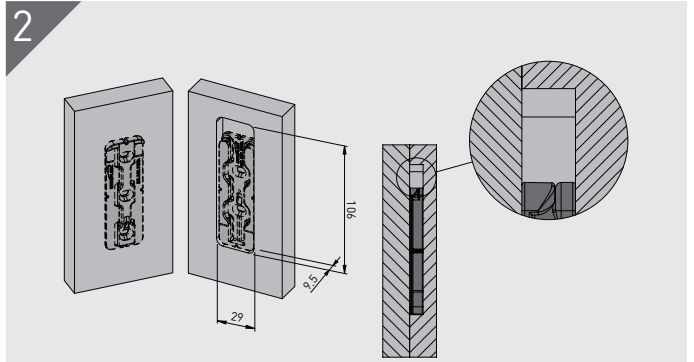

Full Rebate - 1 of the substrate mounting faces is rebating the full depth as shown. Ensure sufficient screw embedment in substrate.

Set-Back Mounting

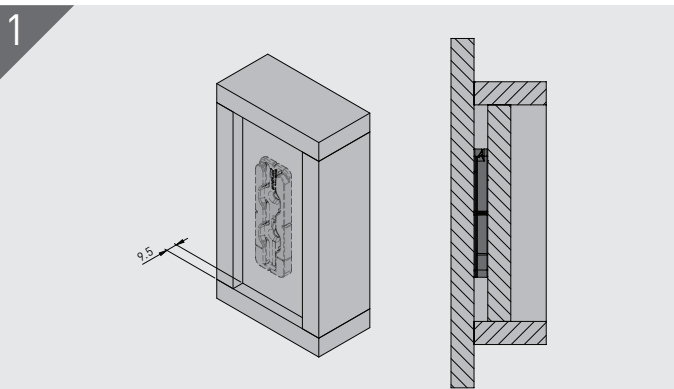

Setting back the mounting face of either the Hook (as shown) or Key by 9.5mm results in a concealed joint without the need to cut rebates.

Installation Aids

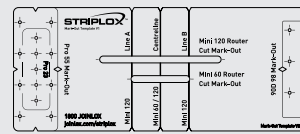

Striplox Mark-Out Template
Developed to aid in the installation of the Striplox Pro 23, Pro 55, 90D 98, Mini 60 and 120.



Striplox Liquidlox
Instant adhesive with a 15 second cure time. Liquidlox delivers a strong and reliable connection between Striplox products and most substrates.

Visit joinlox.com/striplox or call **1800 JOINLOX** to find out more about these installation aids.

Load Capacity

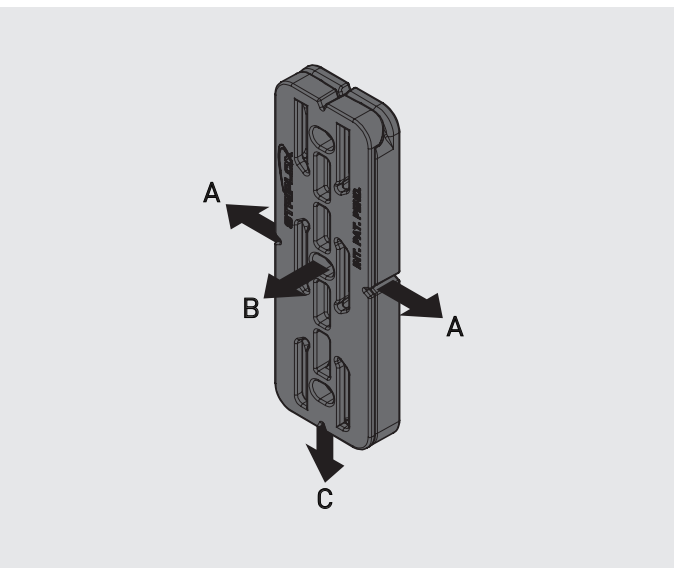

Direction	Indic. Load Capacity
A	110 kg
B	95 kg
C	160 kg

- Tested using particle board and fixed with screws.
- Ensure sufficient screw embedment in substrate.

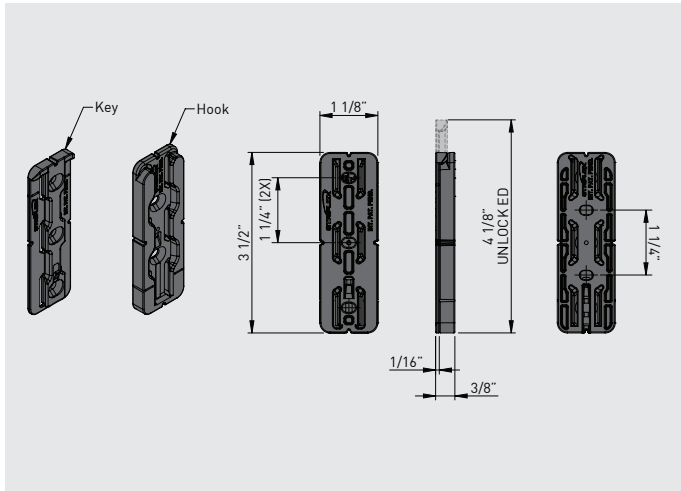

Flush Mounting

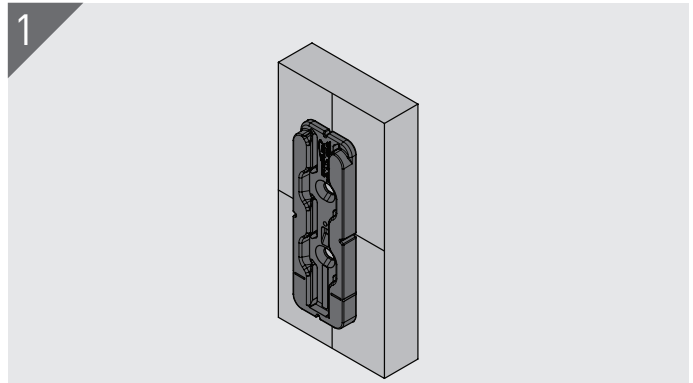

Mark center lines, vertical and horizontal, on both substrates. Flush mounting requires no additional preparation. Line the notches in each component (Hook shown here) with the center lines. **Mark-Out Template** can also be used.

Material	High Strength Reinforced Nylon
Colour	Black
Fixing Method	8G Screws (5x) or Glue

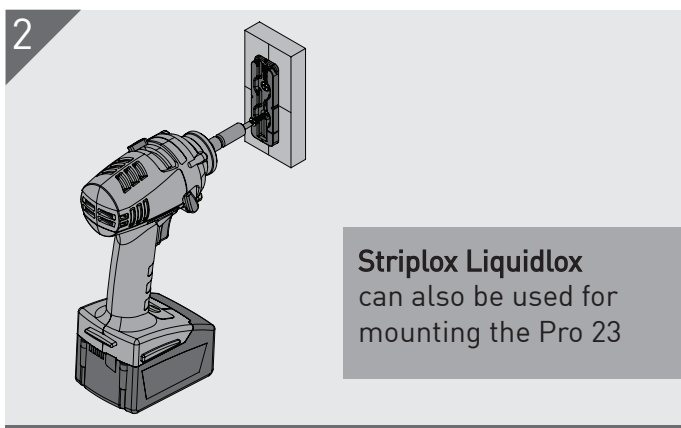

Striplox Liquidlox can also be used for mounting the Pro 23

Hold the component in place and fasten to the substrate with 5 x 8G screws. Repeat for matching component. Ensure sufficient screw embedment in substrate.

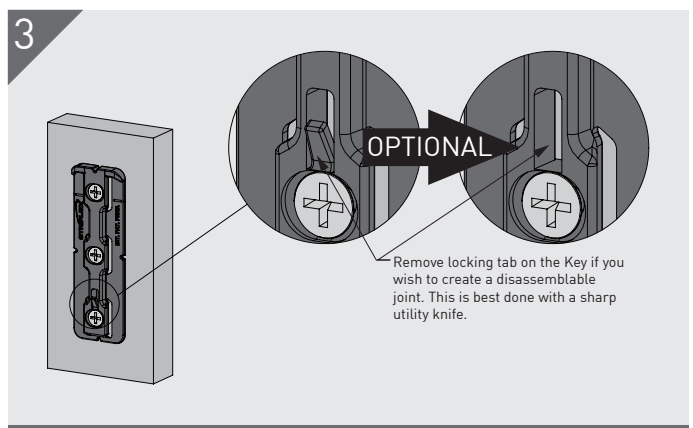

Prior to assembly, establish whether the joint is to be permanent or disassemblable.

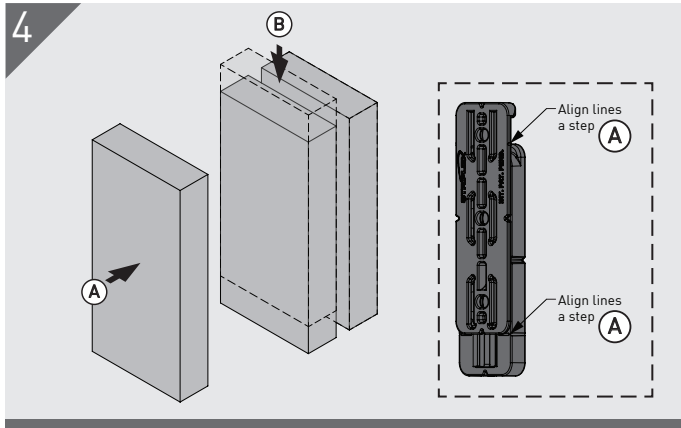

Assembly the joint remembering the Pro 23 only needs to travel 1 pitch for full engagement. Alignment lines are designed into the parts to help with assembly.

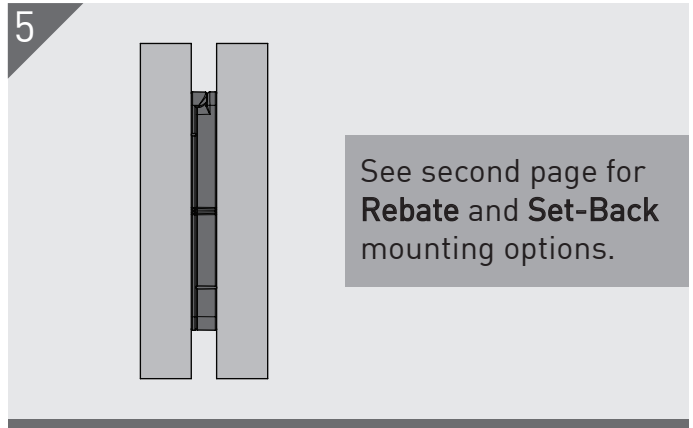

See second page for **Rebate** and **Set-Back** mounting options.

When assembled, the substrates will be separated by the thickness of the engaged Pro 23.

Rebate Mounting

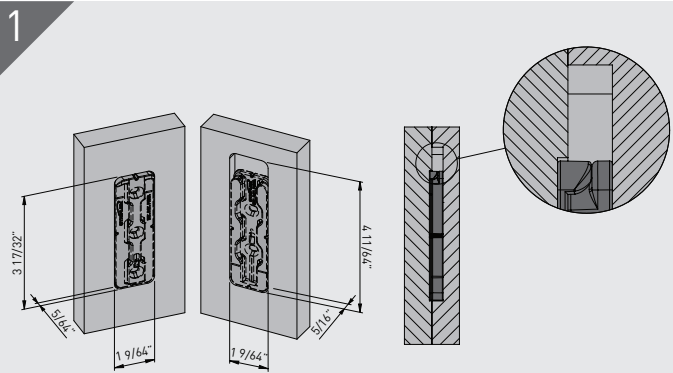

Part Rebate - each substrate mounting face is rebating as shown. Ensure sufficient screw embedment in substrate.

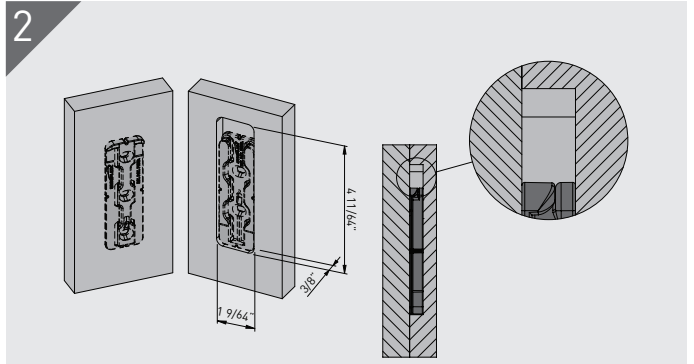

Full Rebate - 1 of the substrate mounting faces is rebating the full depth as shown. Ensure sufficient screw embedment in substrate.

Set-Back Mounting

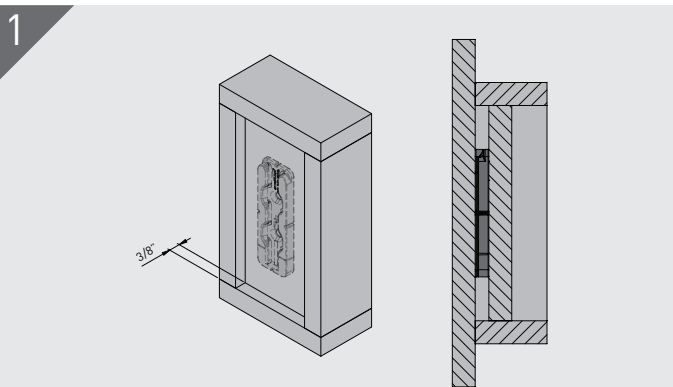

Setting back the mounting face of either the Hook (as shown) or Key by 3/8" results in a concealed joint without the need to cut rebates.

Installation Aids

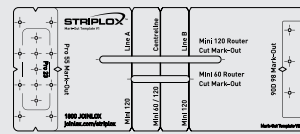

Striplox Mark-Out Template
Developed to aid in the installation of the Striplox Pro 23, Pro 55, 90D 98, Mini 60 and 120.



Striplox Liquidlox
Instant adhesive with a 15 second cure time. Liquidlox delivers a strong and reliable connection between Striplox products and most substrates.

Visit joinlox.com/striplox or call 1800 JOINLOX to find out more about these installation aids.

Load Capacity

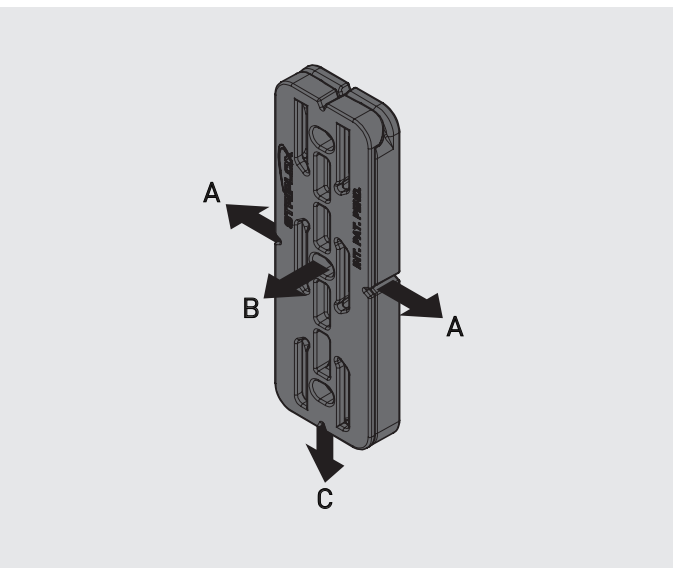

Direction	Indic. Load Capacity
A	242 lb
B	209 lb
C	352 lb

- Tested using particle board and fixed with screws.
- Ensure sufficient screw embedment in substrate.